

## Type A Pallet Cages (THE IDEAL TRANSPORT CAGE)



### BOLTLESS DESIGN – NO TOOLS REQUIRED

- 4 Way Pallet Rack Safe (with positive lock) – all sides
- 4 Way Stackable - Stacks collapsed or assembled
- 4 Way Forklift entry with Anti-Tip Design
- 4 Way Narrow Pallet Jack (520-540mm wide) Entry
- Not suitable for Electric Pallet Jack
- Available in 3 heights – 650mm, 885mm & 1120mm
- Fully removable front & rear gates
- Half drop down front & rear gates fitted to the Medium & Large cages
- Mesh sides 50mm x 50mm x 3.5mm
- SWL – 1000KG (Uniformly distributed load)
- Zinc Plate Finish available with a Sheet or Mesh Floor
- Hot Dip Galv. Finish available with a Mesh Floor only – suitable for external use.
- Stackable 3 high when loaded

## Type A Pallet Cages (Double width)



- Available in 2 heights – 650mm & 1120mm
- Fully removable front & rear gates
- Half drop down front & rear gates fitted to the Large Cage only.
- Mesh sides 50mm x 50mm x 3.5mm
- SWL – 1000KG (Uniformly distributed load)
- Zinc Plate Finish available with a Sheet or Mesh Floor
- Hot Dip Galv. Finish available with a Mesh Floor only – suitable for external use.
- 2 Way Stackable, Stacks collapsed or assembled
- 2 Way Pallet Rack Safe (with positive lock) – 2 sides
- 2 Way Forklift & Pallet Jack Entry, with Anti-Tip Design.
- Not suitable for Electric Pallet Jack
- Spigot Feet
- Stackable 3 high when loaded



## Type A Pallet Cages (Specifications)



Product Code	Description	Dimensions WxDxH (mm)	Floor Type	Finish	
PC 500ZP	Type [A] Small	Internal – 1080 x 1080 x 400 External – 1160 x 1160 x 650 Collapsed height – 360 Weight – 94kg SWL – 1000KG UDL	Sheet Steel	Zinc Plated	
PC 530ZP	Type [A] Small	Internal – 1080 x 1080 x 400 External – 1160 x 1160 x 650 Collapsed height – 360 Weight – 93kg SWL – 1000KG UDL	Mesh	Zinc Plated	
PC 560HDG	Type [A] Small	Internal – 1080 x 1080 x 400 External – 1160 x 1160 x 650 Collapsed height – 360 Weight – 100kg SWL – 1000KG UDL	Mesh	Hot Dip Galvanised	

Product Code	Description	Dimensions WxDxH (mm)	Floor Type	Finish	
PC 505ZP	Type [A] Medium	Internal – 1080 x 1080 x 640 External – 1160 x 1160 x 885 Collapsed height – 360 Weight – 106kg SWL – 1000KG UDL	Sheet Steel	Zinc Plated	
PC 535ZP	Type [A] Medium	Internal – 1080 x 1080 x 640 External – 1160 x 1160 x 885 Collapsed height – 360 Weight – 104kg SWL – 1000KG UDL	Mesh	Zinc Plated	
PC 565HDG	Type [A] Medium	Internal – 1080 x 1080 x 640 External – 1160 x 1160 x 885 Collapsed height – 360 Weight – 111kg SWL – 1000KG UDL	Mesh	Hot Dip Galvanised	

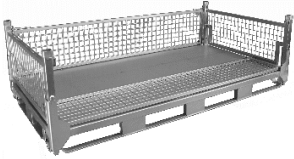
Product Code	Description	Dimensions WxDxH (mm)	Floor Type	Finish	
PC 510ZP	Type [A] Large	Internal – 1080 x 1080 x 880 External – 1160 x 1160 x 1120 Collapsed height – 360 Weight – 117kg SWL – 1000KG UDL	Sheet Steel	Zinc Plated	
PC 540ZP	Type [A] Large	Internal – 1080 x 1080 x 880 External – 1160 x 1160 x 1120 Collapsed height – 360 Weight – 111kg SWL – 1000KG UDL	Mesh	Zinc Plated	
PC 570HDG	Type [A] Large	Internal – 1080 x 1080 x 880 External – 1160 x 1160 x 1120 Collapsed height – 360 Weight – 118kg SWL – 1000KG UDL	Mesh	Hot Dip Galvanised	

## Type A Double Pallet Cages (Specifications)

Product Code	Description	Dimensions WxDxH (mm)	Floor Type	Finish	
PC 515ZP	Type [A] Small Double	Internal – 2110 x 1080 x 400 External – 2200 x 1160 x 650 Collapsed height – 360 Weight – 139kg SWL – 1000KG UDL	Sheet Steel	Zinc Plated	
PC 545ZP	Type [A] Small Double	Internal – 2110 x 1080 x 400 External – 2200 x 1160 x 650 Collapsed height – 360 Weight – 138kg SWL – 1000KG UDL	Mesh	Zinc Plated	
PC 575HDG	Type [A] Small Double	Internal – 2110 x 1080 x 400 External – 2200 x 1160 x 650 Collapsed height – 360 Weight – 136kg SWL – 1000KG UDL	Mesh	Hot Dip Galvanised	

Product Code	Description	Dimensions WxDxH (mm)	Floor Type	Finish	
PC 520ZP	Type [A] Large Double	Internal – 2110 x 1080 x 880 External – 2200 x 1160 x 1120 Collapsed height – 360 Weight – 170kg SWL – 1000KG UDL	Sheet Steel	Zinc Plated	
PC 550ZP	Type [A] Large Double	Internal – 2110 x 1080 x 880 External – 2200 x 1160 x 1120 Collapsed height – 360 Weight – 166kg SWL – 1000KG UDL	Mesh	Zinc Plated	
PC 580HDG	Type [A] Large Double	Internal – 2110 x 1080 x 880 External – 2200 x 1160 x 1120 Collapsed height – 360 Weight – 180kg SWL – 1000KG UDL	Mesh	Hot Dip Galvanised	

## Type B Pallet Cages

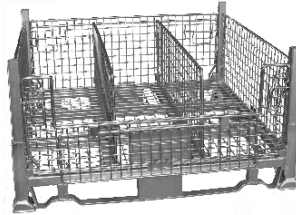

Dividable



### BOLTLESS DESIGN – NO TOOLS REQUIRED



Rack Safe



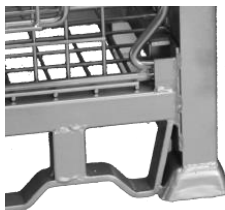

Collapsible





Cup Feet

- Stacks collapsed or assembled
- 4 Way Stackable
- 4 Way Pallet Rack Safe (with positive lock) – all sides
- Available in 2 Heights 600mm & 920mm
- Stackable 3 high when loaded
- 4 Way Forklift entry with Anti-Tip Design
- 4 Way Narrow Pallet Jack (520-540mm wide) Entry
- Not suitable for Electric Pallet Jack
- Fully removable front & rear gates
- Half drop down front gates
- Mesh sides 40mm x 40mm x 5mm
- SWL – 1000KG (Uniformly distributed load)
- Zinc Plate Finish available with a Sheet or Mesh Floor
- Hot Dip Galv. Finish available with a Mesh Floor only – suitable for external use.
- Front to back dividers available for small cages only (600mm high)

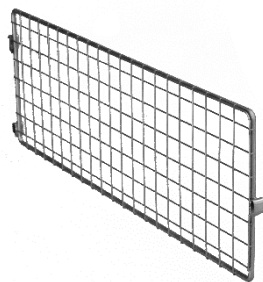
## Type B Pallet Cages (Specifications)

Product Code	Description	Dimensions WxDxH (mm)	Floor Type	Finish	
PC 600ZP	Type [B] Small	Internal – 1070 x 1070 x 390 External – 1172 x 1172 x 600 Collapsed height – 330 Weight – 93kg SWL – 1000KG UDL	Sheet Steel	Zinc Plated	
PC 620ZP	Type [B] Small	Internal – 1070 x 1070 x 390 External – 1172 x 1172 x 600 Collapsed height – 330 Weight – 85kg SWL – 1000KG UDL	Mesh	Zinc Plated	
PC 640HDG	Type [B] Small	Internal – 1070 x 1070 x 390 External – 1172 x 1172 x 600 Collapsed height – 330 Weight – 89kg SWL – 1000KG UDL	Mesh	Hot Dip Galvanised	
PC 610ZP	Divider (Front to Back)	375mm High, (50x50mesh) Weight – 3kg * Small Cage Only	Zinc Plated		

Product Code	Description	Dimensions WxDxH (mm)	Floor Type	Finish	
PC 605ZP	Type [B] Large	Internal – 1070 x 1070 x 720 External – 1172 x 1172 x 920 Collapsed height – 330 Weight – 112kg SWL – 1000KG UDL	Sheet Steel	Zinc Plated	
PC 625ZP	Type [B] Large	Internal – 1070 x 1070 x 720 External – 1172 x 1172 x 920 Collapsed height – 330 Weight – 105kg SWL – 1000KG UDL	Mesh	Zinc Plated	
PC 645HDG	Type [B] Large	Internal – 1070 x 1070 x 720 External – 1172 x 1172 x 920 Collapsed height – 330 Weight – 110kg SWL – 1000KG UDL	Mesh	Hot Dip Galvanised	

## Type C Eco Pallet Cages – Small

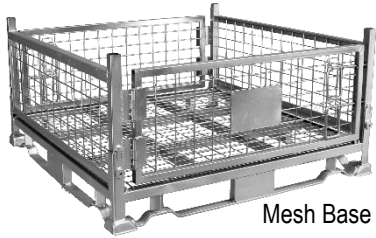

Mesh Base

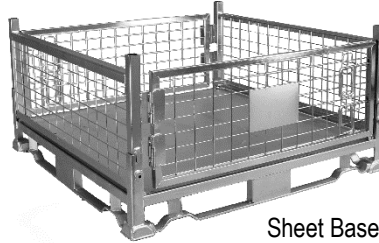

Sheet Base

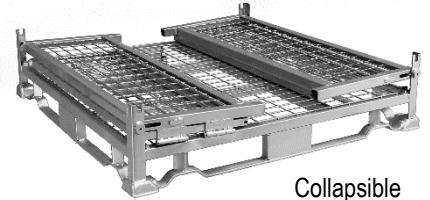

Collapsible



Rack Safe

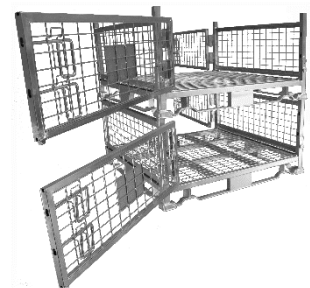
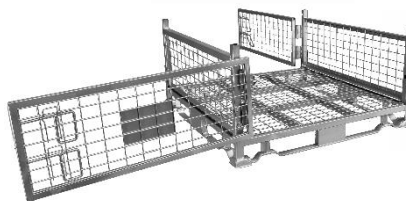
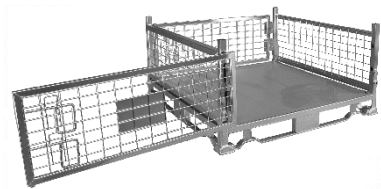

### BOLTLESS DESIGN – NO TOOLS REQUIRED

- 4 Way Pallet Rack Safe (with positive lock) – all sides
- 4 Way Forklift entry with Anti-Tip Design
- 4 Way Narrow Pallet Jack (520-540mm wide) Entry
- Not suitable for Electric Pallet Jack
- Available 600mm high
- Mesh sides 75mm x 50mm x 3.5mm
- SWL – 750KG (Uniformly distributed load)
- Zinc Plate Finish available with a Sheet or Mesh Floor
- Stackable 3 high when loaded
- Front & Back swing gates

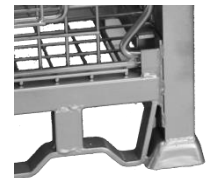
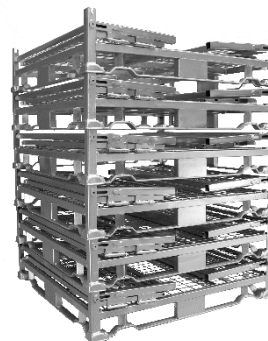

Cup Feet

## Type C Eco Pallet Cages – Large

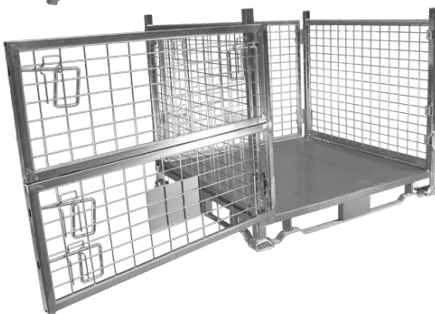
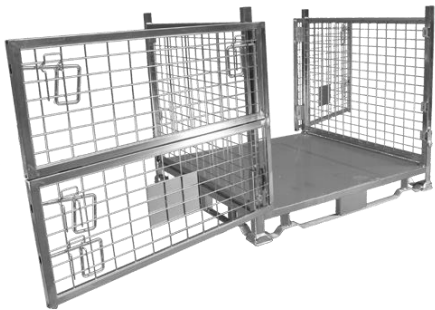
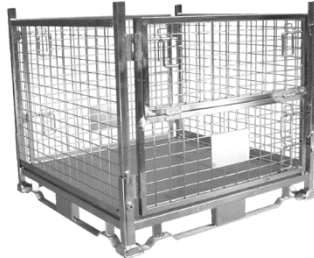

### BOLTLESS DESIGN – NO TOOLS REQUIRED

- 4 Way Pallet Rack Safe (with positive lock) – all sides
- 4 Way Forklift entry with Anti-Tip Design
- 4 Way Narrow Pallet Jack (520-540mm wide) Entry
- Not suitable for Electric Pallet Jack
- Available 1000mm high
- Mesh sides 75mm x 50mm x 3.5mm
- SWL – 750KG (Uniformly distributed load)
- Zinc Plate Finish available with a Sheet or Mesh Floor
- Stackable 3 high when loaded
- Front & Back swing gates
- Half Drop Down Panel on front gate





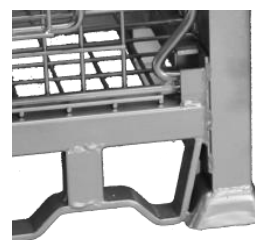

Rack Safe

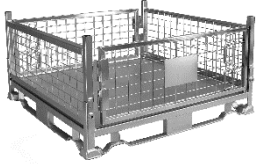

Cup Feet

## Type C Eco Pallet Cages (Specifications)

Product Code	Description	Dimensions WxDxH (mm)	Floor Type	Finish	
PC 400ZP	Type [C] Small	Internal – 1060 x 1060 x 400 External – 1170 x 1170 x 600 Collapsed height – 280mm Weight – 69kg SWL – 750KG UDL	Sheet Steel	Zinc Plated	
PC 410ZP	Type [C] Small	Internal – 1060 x 1060 x 400 External – 1170 x 1170 x 600 Collapsed height – 280mm Weight – 59kg SWL – 750KG UDL	Mesh	Zinc Plated	

Product Code	Description	Dimensions WxDxH (mm)	Floor Type	Finish	
PC 440ZP	Type [C] Large	Internal – 1060 x 1060 x 800 External – 1170 x 1170 x 1000 Collapsed height – 335mm Weight – 86kg SWL – 750KG UDL	Sheet Steel	Zinc Plated	
PC 450ZP	Type [C] Large	Internal – 1060 x 1060 x 800 External – 1170 x 1170 x 1000 Collapsed height – 335mm Weight – 76kg SWL – 750KG UDL	Mesh	Zinc Plated	



## STILLAGES

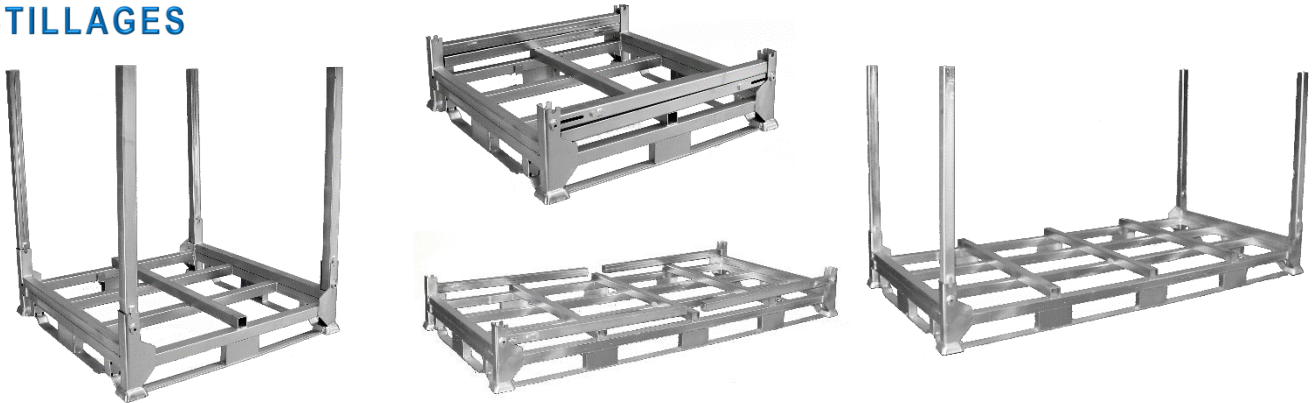

### BOLTLESS DESIGN – NO TOOLS REQUIRED, NO LOOSE PARTS

- Available in 2 sizes: 1200mm Wide & 2300mm Wide
- Collapsible
- Stackable 2 high when loaded
- SWL – 1000KG (Uniformly distributed load)
- 2 way pallet rack safe (with positive lock) 2 sides
- 2 way forklift and pallet jack entry with anti-tilt design
- Not suitable for Electric Pallet Jack
- Cup foot
- Zinc Plated Finish
- Built in fork-tine spacers on base

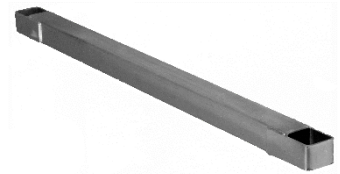

## STILLAGES (Specifications)

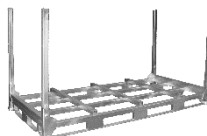
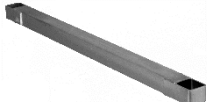
Product Code	Description	Dimensions WxDxH (mm)	Finish	
PC 810ZP	Stillage Small	Internal – 1010 x 1010 x 1000 External – 1160 x 1160 x 1200 Collapsed height – 340mm Weight – 74kg SWL – 1000KG UDL	Zinc Plated	
PC 830ZP	Stillage Large	Internal – 2140 x 1010 x 1000 External – 2300 x 1160 x 1200 Collapsed height – 305mm Weight – 102kg SWL – 1000KG UDL	Zinc Plated	
PC 850ZP	Stillage Spacer Bar	1120 x 60 x 60 mm Weight – 6kg	Zinc Plated	

## Pallet / Cage Trolleys

To suit :

- Single Type Pallet Cages
- Australian Standard Hardwood Pallets
- Zinc Plated Finish
- Heavy Duty Swivel / Lockable wheels.
- SWL – 1000kg
- Supplied in Component Form (frame, castors, bolts & washers)



Product Code	Description	Dimensions WxDxH (mm)	Finish	
PC 720ZP	Pallet / Cage Trolley (Castors packed loose for transport)	1175 x 1175 x 300 Weight – 51kg SWL – 1000KG UDL	Zinc Plated	

## Mesh Pallet Collars (ONE PIECE) – PALLET NOT INCLUDED

**BOLTLESS DESIGN – NO TOOLS REQUIRED**

- To suit :
- Australian Standard Hardwood Pallets
- Zinc Plated Finish
- Collapsible
- 400mm high - can be multi stacked to create additional height
- 50mm x 50mm x 3.5mm Mesh
- Front gate can swing open if 2 sides are fixed to pallet

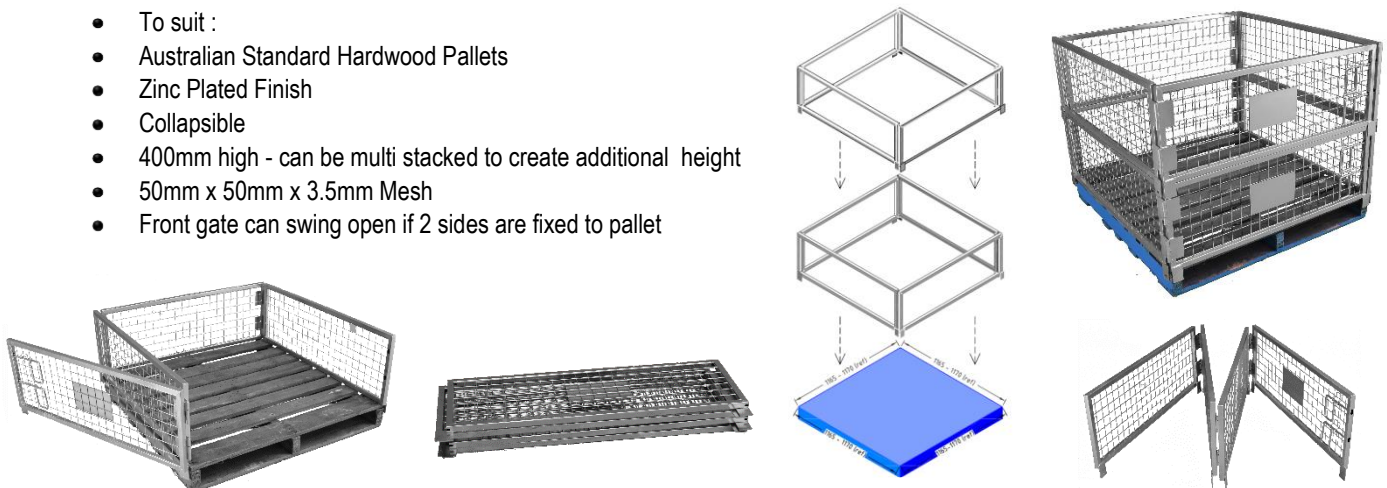

\*Pallet not included

Product Code	Description	Dimensions WxDxH (mm)	Finish	
PC 700ZP	Mesh Pallet Collar  *Pallet not included	1170 x 1170 x 400 Collapsed – 1190 x 450 x 150 Weight – 19kg	Zinc Plated	